

## PTD-BRK/FS-2A

### Powered Current Sensing Trip Amplifier – Brake Motors



#### GENERAL DESCRIPTION

The PTD-BRK/FS is a fully isolated dual trip amplifier/alarm module that accepts an AC or DC current input from 0 Amp up to 2 Amps from up to a 415V supply line.

The PTD-BRK/FS provides a trip relay output which operates between the fixed “Base” and “Maximum” current setting. It works as a stand-alone alarm unit and operates as a window comparator where the relay de-energises if the signal goes below 60mA or above 500mA. The relay has a fixed dead-band of 20%.

#### FEATURES

- ◆ Wide Operating Voltage Range
- ◆ Set Point Trip Status LED's
- ◆ Trip window factory set with status LED's
- ◆ Very small footprint area
- ◆ DIN & G rail mounting style
- ◆ Low power consumption
- ◆ 600V HBC 3.15A Input Protection Fuse

#### TECHNICAL DATA

**Power Supply.**  
 Nominal Supply 22V - 60Vac/dc  
 VA Rating Typically 1.2VA  
 Max Power Typically 1.3VA with relay energised.

**Input (Internally Fuse Protected 3.15A SIBA 189-020)**  
 Amps AC or DC 0 Amp to 1Amps (Terms 1-3)  
 0 Amp to 2Amps (Terms 1-2)  
 Base Current (1A) 60mA to 500mA  
 Base Current (2A) 120mA to 1000mA  
 Volts (max) 500Vac/300Vdc on terms 1 & 3  
 Input Resistance < 0.1 Ohm

**Output (Single relay c/o output)**  
 Set Point Relay c/o contact  
 Under Current and/or Over Current fixed set points.  
 For 0 – 2Amp 0– 10Vdc (2A = 10V)

#### GENERAL SPECIFICATION

Accuracy 2.5% of span  
 Linearity 1% of span  
 Response time 0 to 110% step in 1.5 sec  
 Drift 0.25% per Deg C  
 Isolation level Greater than 500Vrms  
 Dead Band Fixed at 20% of relay set.  
 Trip Settings Under Current - 50% of Base  
 Over Current + 50% of Base

**Output Relay**  
 Contact Configuration 1 Form C (SPDT)  
 Max Voltage Up to 220 Vdc or 250 Vac  
 Max Power Rating 30 Watts or 62.5 VA  
 Max Cont. Current 2 Amps (non-inductive)  
 Vibration 20G  
 Shock 75G  
 Life Expectancy Mechanical 10 x 10<sup>6</sup>

**Mechanical**  
 Operating Temp 0 to 60 Deg C  
 Store Temp -25 to +75 Deg C  
 Mounting Style DIN & G Rail  
 Terminals 2.5mm<sup>2</sup> / 12AWG  
 Housing Material KRILEN  
 Dimensions 79 x 106 x 25mm wide  
 Weight 110 grams

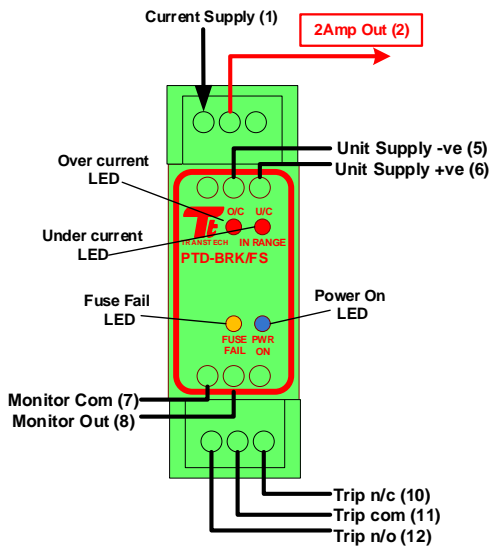

CONNECTION DIAGRAM

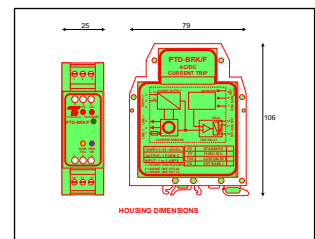

## PTD-BRK/FS-2A

### Powered Current Sensing Trip Amplifier – Brake Motors

#### IMPORTANT

1. THERE ARE NO INTERNAL SETTINGS REQUIRED IN THE FIELD.

2. AT VERY LOW CURRENT SETTINGS THE PTD-BRK/F MAY BE AFFECTED BY NOISE INTERFERENCE.

3. **IMPORTANT NOTE:**  
If supply is removed to the PTD-BRK the Fuse Fail LED will be reset.

#### RELAY OPERATION

The relay is set to be “normally energised”, that is when DC power is applied to the PTD and the signal is above the lower trip point and below upper trip point; the relay is energised. If the power supply goes off or the signal is above or below the set points (fault) the relay will de-energise.

#### CALIBRATION & SET-UP INSTRUCTIONS:-

**PTD-BRK/FS. (Standard version – factory set).**

**From Nov 2013** the low trip is set to 60mA and the high trip is set to 500mA (for 1Amp connection). For the 2Amp connection the low trip is set to 120mA and the high trip is set to 1000mA.

Top decade switches masked off – **DO NOT ADJUST**

#### Other PTD-BRK/F versions are:

**PTD-BRK/FF (Fixed threshold set to +/- 50% of base I)**

Turn the fine decade switch to zero (0) and coarse switch to nine (9) Link terminals 7 – 9

With a load connected and the “In Range” Green LED on adjust the coarse decade switch slowly down (anti-clock) until the LED goes off.

Now adjust the fine decade switch slowly up (clockwise) until the Green LED comes on – the base current is now set.

Remove the link between terminals 7 – 9

#### NOTES:-

1. The sensed current can be measured by connecting a DVM ranged 0 – 10VDC between terminals 7 and 8.

2. The base current is set by a combination of:

Input current (either 0-1 or 0-2 amp)

Top of panel switches (coarse and fine) where:

Coarse = 10% of range | Fine = 1% of range.

For other modes of operation consult factory.