

Transtech Conveyor Monitoring System



MONITOR FAULT – FEATURES

COMMUNICATIONS FEATURES

If the communications is lost between the PLC Master Controller and the II-056 Master Module, the PLC will not be able to talk to the II-056 Master and an alarm condition should be generated within the PLC.

The II-056 has an electronic alarm output acting as a “watchdog” alarm, this can be hard wired into the PLC and the normally healthy closed status monitored, (the output contact is open with no power and closes if power is on and the II-056 processor is running and communications are all OK).

If the communications is lost between the Master Module and the field modules (due to a short or open circuit), the Master Module will report a fault back to the PLC and identify which furthest module it can communicate with.

If the II-056 Master Module loses power, the normally closed electronic alarm output will open, acting as a watchdog output. If the communications line to the field modules is short circuited, the Master Module communicates to the field module before the short or break and reports a fault, once the short is removed or the open corrected the system will resume working.

If the power cable to the field modules is short circuited, the II-056 Master Module power supply is designed to actively limit the current to the field to approx.100mA causing an alarm output. When the short is removed and the power is restored, the alarm output auto resets.

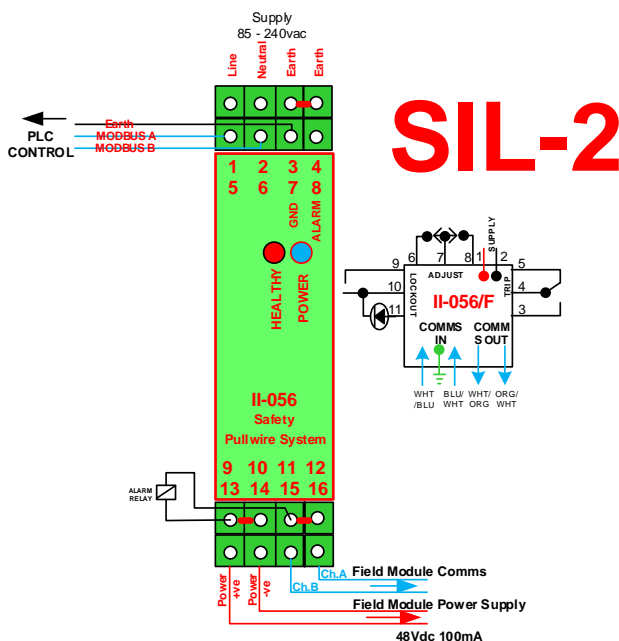

SOFTWARE FEATURES

SCHEMATIC DIAGRAM

If the power and/or the communications cables are open circuited, the II-056 Master Module software cannot communicate with the field modules and reports a fault. The II-056 Master Module identifies the last field module it can communicate with and reports to the PLC the next module and all remaining are in “fault” condition.

If the cables from the Pull wire switch input to the field module are shorted or opened, the field module has a “window” design type input which detects either a short circuit or open circuit and reports the “fault” condition to the II-056 Master Module.

If the software fails in the II-056 Master Module, the module has an internal electronic watchdog which resets the micro-processor.

The whole II-056 system is self-configuring, therefore the last module permanently reports a fault by the very fact it is last in line. The PLC would know, for example, that there are 55 modules despite the system being set for 50. It is also possible to set a unique serial number in each module so that the PLC reads them sequentially on start-up and the user can set relevant site tags for each module.

EARTH CONNECTIONS

The Master Module input has an Earth connection and the power to the field modules is SELV compliant therefore must NOT be earthed. Care needs to be taken that the 4 field wires are not shorted to Earth, if the field wire is earthed the circuit is no longer SELV compliant.

SAFETY INTEGRITY LEVEL (SIL)

Both the Master Module and the field interface II-056 have been Third Party determined to meet IEC 61508, achieving a SIL 2 safety level. The two products are therefore suitable to be included in a SIL 2 Safety Instrument System (SIS).